

**RUSTIC BARN STYLE
PICTURE FRAMES
BUILD PLANS**



TABLE OF CONTENTS

THANK YOU	3
CREDIT – INSPIRATION FOR FRAMES	4
PARTS LIST	5
CUT LIST	
STEP 1 – 4 LONG PIECES	6
STEP 2 – 6 SHORT PIECES	7
STEP 3 – 2 HARDWOOD SUPPORT BOARDS	8
STEP 4 – BACKERBOARD	9
STEP 5 – CUTTING A RABBET IN THE SHORT PIECES	10
STEP 6 – TRIMMING THE LONG PIECES FOR THE PICTURE	11
STEP 6 – TRIMMING THE LONG PIECES FOR THE PICTURE – LARGE VIEW	12
STEP 7 – ROUTING OUT THE INLAY	13
STEP 7 – ROUTING OUT THE INLAY – LARGE VIEW	14
STAINING	
STEP 8 – DARK WALNUT	15
STEP 9 – CLASSIC GRAY	16
THE GLUE UP	
STEP 10 – GLUING WITH BRADS	17
STEP 11 – CLAMPING WITH CAUL BOARDS	18
STEP 12 – INSERTING POINTS AND INSTALLING THE WALL HANGER	19



THANK YOU!

I WANTED TO TAKE A BRIEF MOMENT TO SIMPLY SAY THANK YOU FOR YOUR SUPPORT. IT TAKES A LOT OF WORK TO PLAN, CREATE, AND BUILD PROJECTS, AND EVEN MORE WORK TO CREATE THE VIDEOS AND PLANS TO SHARE WITH YOU. NONE OF IT WOULD BE POSSIBLE WITHOUT YOUR SUPPORT!

IF YOU HAVEN'T ALREADY, PLEASE CONSIDER SUBSCRIBING TO THE  YOUTUBE CHANNEL - AND PLEASE ALSO CONSIDER SHARING OUR POSTS AND VIDEOS WITH FRIENDS AND FAMILY THAT WOULD ENJOY THE CONTENT. PLEASE LEAVE US A COMMENT - AND LET US KNOW IF THERE'S SOMETHING SPECIFIC YOU'D LIKE TO SEE ON THE CHANNEL!

AS YOU WORK THROUGH THESE PLANS, PLEASE LET US KNOW IF YOU FIND AN ERROR - OR IF SOMETHING DOES NOT MAKE SENSE - SO THAT WE CAN HELP. SIMPLY USE THE EMAIL ADDRESS LISTED BELOW.

AGAIN, I SINCERELY CANNOT THANK YOU ENOUGH FOR THE SUPPORT. I HOPE YOU ENJOY THE CHANNEL, THE CONTENT, AND THESE PLANS.

SINCERELY,

 WWW.YOUTUBE.COM/@PROBLEMSAWED

 WWW.PROBLEMSAWED.COM

 JUSTIN@PROBLEMSAWED.COM



CREDIT – INSPIRATION FOR FRAMES

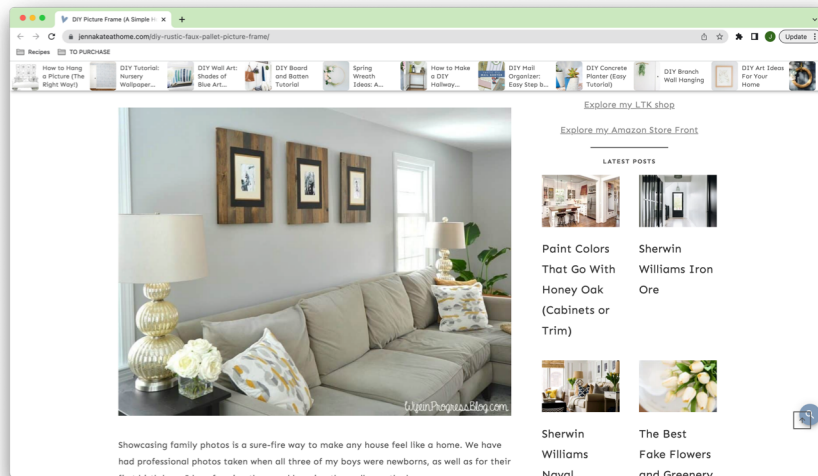
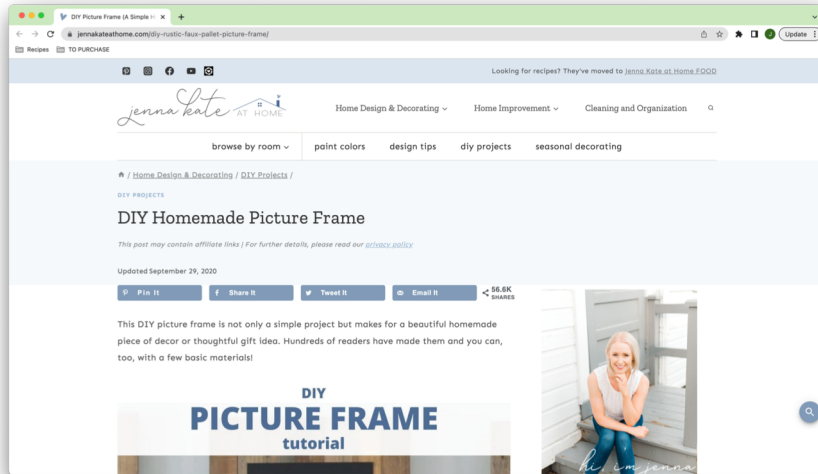

I FIRMLY BELIEVE IN GIVING CREDIT WHERE CREDIT IS DUE ...

WHEN LOOKING AT DIFFERENT PICTURE FRAME STYLES ONLINE A COUPLE OF YEARS AGO, I CAME ACROSS *jenna kate AT HOME*

ON HER WEBSITE, JENNA SHOWS HOW TO BUILD FRAMES USING SMALL WIDTH WOOD AND USING 2 DIFFERENT STAINS TO GIVE THE FRAMES A RUSTIC FEEL.

I TOOK HER IDEA AND AND CHANGED IT TO INCLUDE INSET GLASS – PLEASE CHECK HER WEBSITE OUT FOR MORE. GREAT IDEAS: WWW.JENNAKATEATHOME.COM



PARTS LIST

- 2 – 1" X 3" X 8' PINE BOARDS (WILL CUT)
**PURCHASE AT YOUR LOCAL
HARDWARE STORE**
- 2 – 2" X 16" HARDWOOD (CAN CUT TO SIZE)
**PURCHASE AT YOUR LOCAL
HARDWARE STORE**
- 1 – BRAD NAILS OR STAPLES
**PURCHASE AT YOUR LOCAL
HARDWARE STORE**
- 1 – WOOD GLUE
[AMAZON LINK](#)
- 1 – CAN OF MINWAX DARK WALNUT STAIN
[AMAZON LINK](#)
- 1 – CAN ON MINWAX CLASSIC GRAY STAIN
[AMAZON LINK](#)
- 1 – POINT GUN OR PUSH POINTS
[PUSH POINTS AMAZON LINK](#)
[POINT GUN AMAZON LINK](#)
- 1 – FRAME WALL HANGER
[AMAZON LINK](#)

ESTIMATED COST

PART	PRICE
1" X 3" X 8' PINE WOOD	\$8.22
OAK HARDWOOD	\$8.69
BRAD NAILS – EST. COST	\$5.00
WOOD GLUE	\$19.80
DARK WALNUT STAIN - 8 OZ.	\$16.77
CLASSIC GRAY STAIN – 1 QT.	\$13.48
PUSH POINTS	\$2.48
ESTIMATED TOTAL:	\$74.44

THE ESTIMATED TOTAL INCLUDES GLUE, STAIN, AND PUSH POINTS IN QUANTITIES GREATER THAN NEEDED. EACH ADDITIONAL FRAME WOULD ONLY COST APPROXIMATELY \$17.00 TO BUILD.

**prices subject to change*

For a complete parts list with clickable links, visit: www.ProblemSawed.com/RusticFrames



CUT LIST – BASED ON FRAME SIZE OF 22" X 17 1/2"

STEP 1

CUT 4 PIECES OF 1" X 3" AT A LENGTH OF 22" EACH. EACH PIECE SHOULD BE CUT AT A 90° ANGLE.

QTY: 4

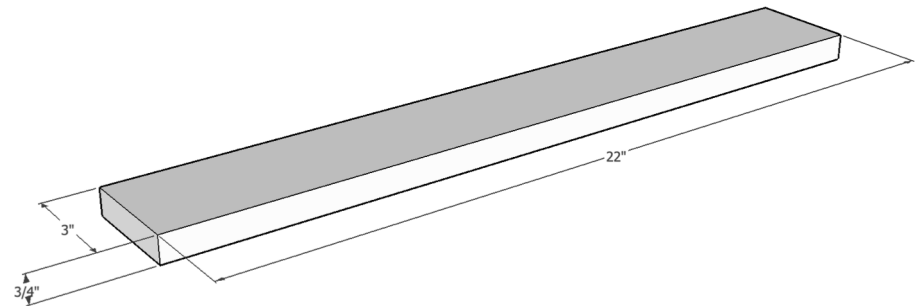

CUT LIST – BASED ON FRAME SIZE OF 22" X 17 1/2"

STEP 2

CUT 6 PIECES OF 1" X 3" AT A LENGTH OF 4 3/4" EACH. EACH PIECE SHOULD BE CUT AT A 90° ANGLE.

QTY: 6

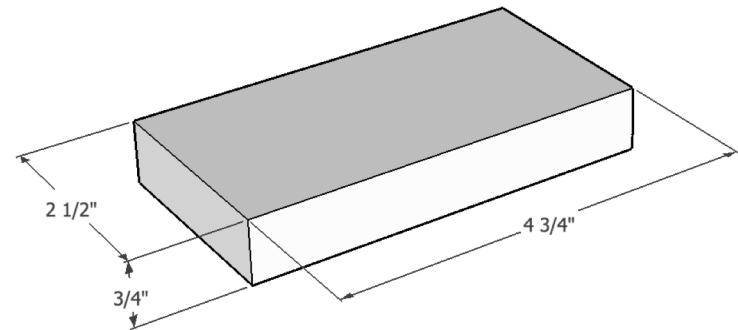

CUT LIST – BASED ON FRAME SIZE OF 22" X 17 1/2"

STEP 3

CUT 2 PIECES OF THE OAK (OR SIMILAR) HARDWOOD AT A LENGTH OF 16" EACH. EACH PIECE SHOULD BE CUT AT A 90° ANGLE.

QTY: 2

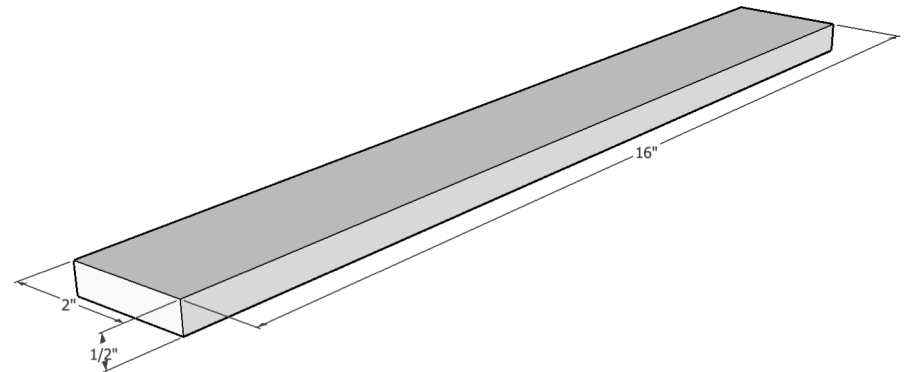

CUT LIST – BASED ON FRAME SIZE OF 22" X 17 1/2"

STEP 4

USING THE 1/4" BACKERBOARD, CUT A
RECTANGLE TO THE FOLLOWING SIZE:

QTY:1

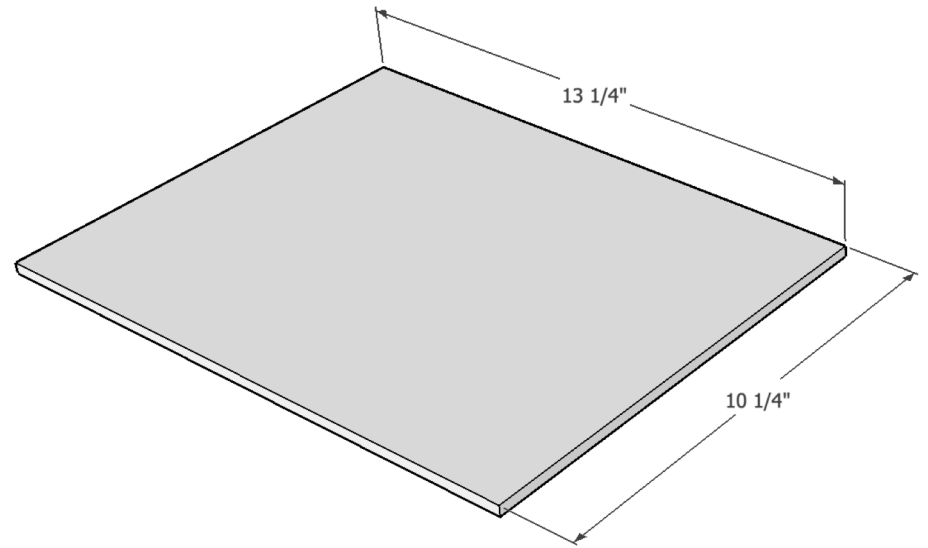

CUT LIST – BASED ON FRAME SIZE OF 22” X 17 1/2”

STEP 5

USING A ROUTER, DADO STACK WITH YOUR TABLE SAW, OR HAND SAWS – REMOVE A 1/2” SQUARE FROM ONE END OF THE SMALL STYLE PIECES.

QTY: 6

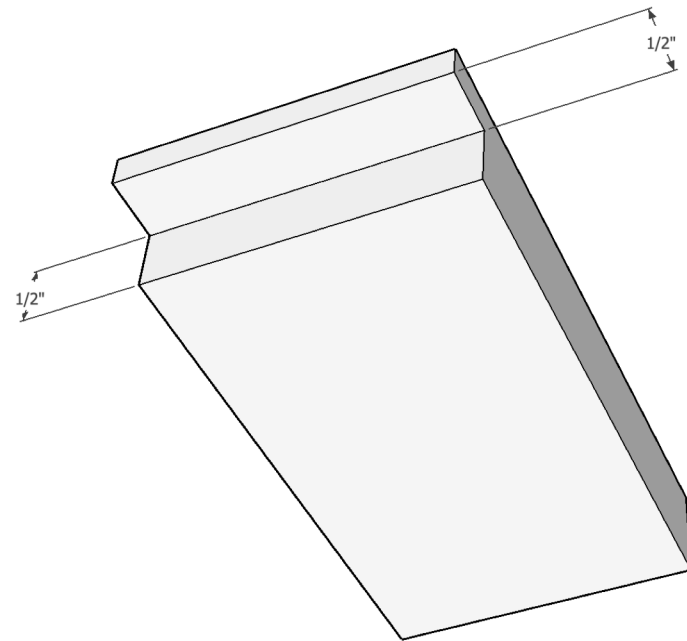

CUT LIST – BASED ON FRAME SIZE OF 22” X 17 1/2”

STEP 6

SELECT 2 OF THE PIECES OF WOOD CUT IN STEP 1.

USING A JIGSAW, REMOVE A 1” X 12 1/2” SECTION OF WOOD FROM A LONG EDGE.

THIS SECTION SHOULD BE CENTERED 4 3/4” FROM EACH EDGE.

QTY: 2

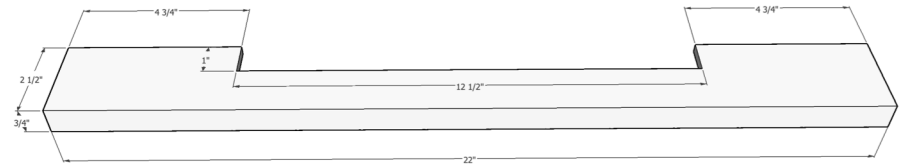

***ENLARGED PICTURE ON NEXT PAGE



CUT LIST – BASED ON FRAME SIZE OF 22" X 17 1/2"

STEP 6

QTY: 2

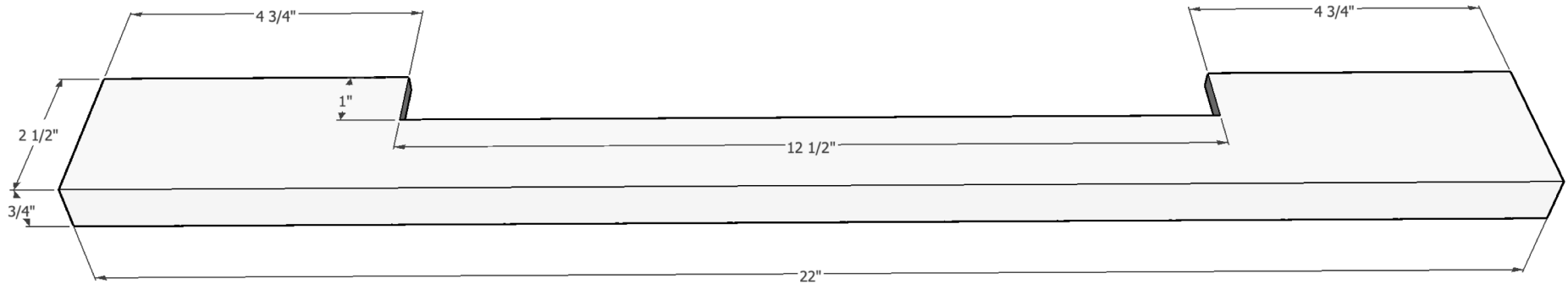

***ENLARGED PICTURE FROM PREVIOUS PAGE



CUT LIST – BASED ON FRAME SIZE OF 22" X 17 1/2"

STEP 7

USING A ROUTER, ROUTE AN "INLAY" SECTION OF THE WOOD TO ALLOW THE PICTURE AND GLASS TO SET INSIDE THE FRAME.

THE ROUTE SHOULD BE 1/2" DEEP BY 1/2" WIDE. YOU MAY NEED TO USE A CHISEL TO SQUARE THE CORNERS.

QTY: 2

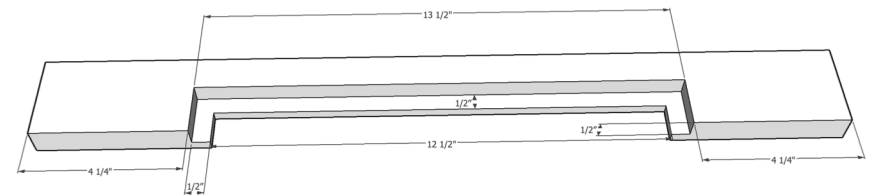

***ENLARGED PICTURE ON NEXT PAGE



CUT LIST – BASED ON FRAME SIZE OF 22" X 17 1/2"

STEP 7

QTY: 2

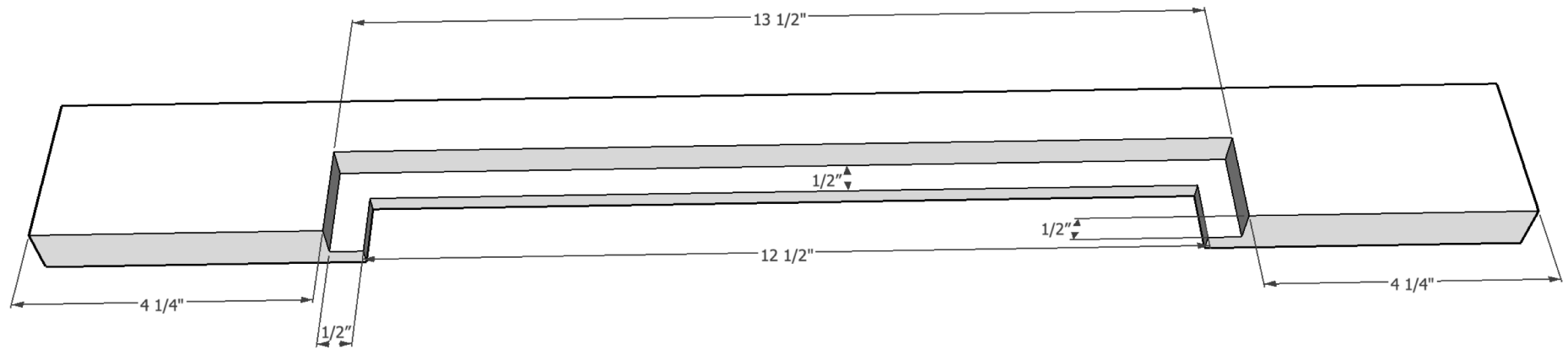

***ENLARGED PICTURE FROM PREVIOUS PAGE



STAINING – BASED ON FRAME SIZE OF 22” X 17 1/2”

STEP 9

ONCE YOU ARE FINISHED STAINING THE WOOD PIECES WITH DARK WALNUT, BEGIN STAINING THE PIECES USING THE CLASSIC GRAY STAIN.

***NOTE – MAKE SURE YOU STAIN THE SHORTER PIECES IN PAIRS – LEAVING THE STAIN ON THE PAIRS OF WOOD CONSISTENTLY AND WIPING THE STAIN OFF AT THE SAME TIME. SEE IMAGE.



***NOTE – MAKE SURE YOU STAIN THE SHORTER PIECES IN PAIRS.

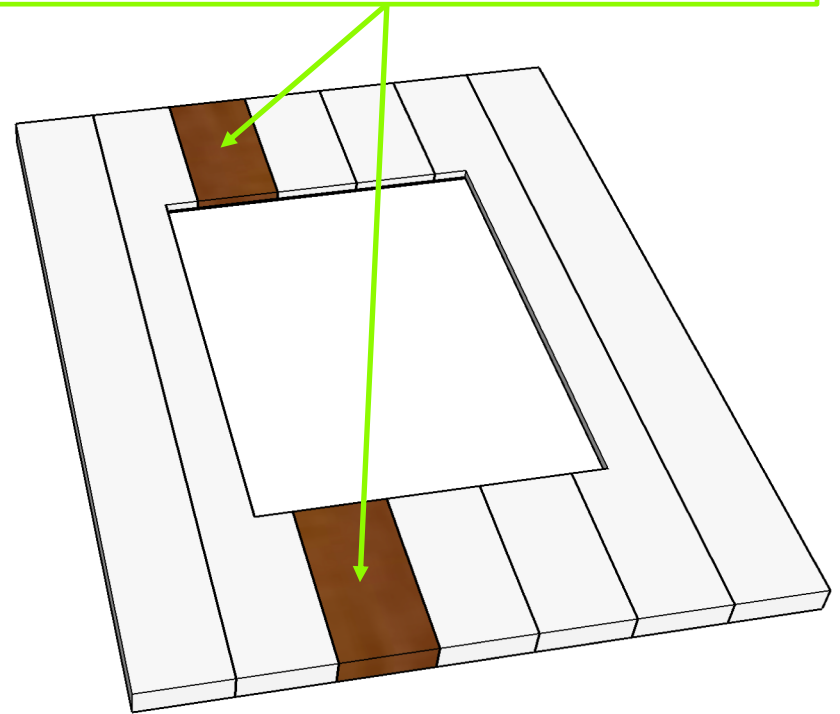

THE GLUE UP – BASED ON FRAME SIZE OF 22” X 17 1/2”

STEP 10

ONCE ALL THE STAIN IS DRY AND YOU ARE SATISFIED WITH THE LOOK OF THE WOOD, PUT THE PIECES OF WOOD FACE DOWN ON A TABLE. THEN, COVER ONE SIDE OF THE HARDWOOD WITH WOOD GLUE, AND PLACE IT ON THE BACK OF THE TOP AND BOTTOM OF THE FRAME (SEE IMAGE).

***YOU SHOULD NOT GLUE THE SIDES OF THE INDIVIDUAL BOARDS. THIS GLUE WILL NOT WORK DUE TO THE STAIN, IT WILL SEEP OUT, AND YOU DO NOT WANT THE BOARDS TO BE "PERFECTLY" ALIGNED.

TO ENSURE THE FRAME IS GLUED PROPERLY, YOU SHOULD ALSO BRAD NAIL/STAPLE THE HARDWOOD IN PLACE.

ONLY GLUE THE CUT FRAME TO THESE BACK SUPPORT BOARDS

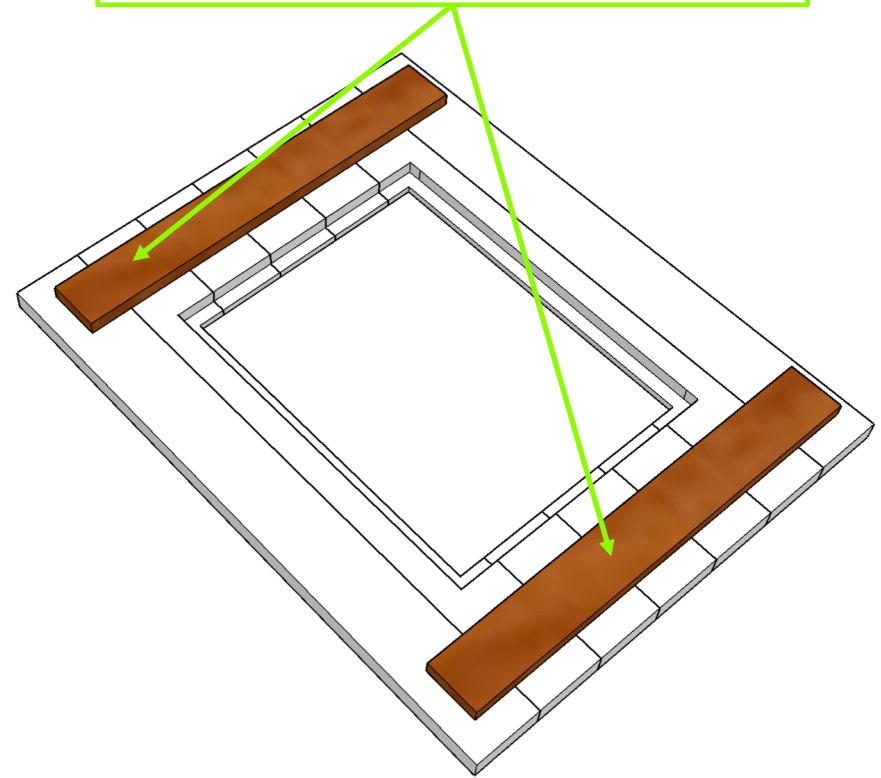

THE GLUE UP – BASED ON FRAME SIZE OF 22” X 17 1/2”

STEP 11

IF YOU HAVE WOOD CLAMPS, USE SOME CAUL BOARDS AND CLAMP THE HARDWOOD PIECES DOWN TO ENSURE THE FRAME DOES NOT BEND WHILE THE GLUE SETS. (SEE IMAGE)

LET THE GLUE FULLY CURE FOR 48 HOURS.

STRAIGHT
CAUL BOARDS

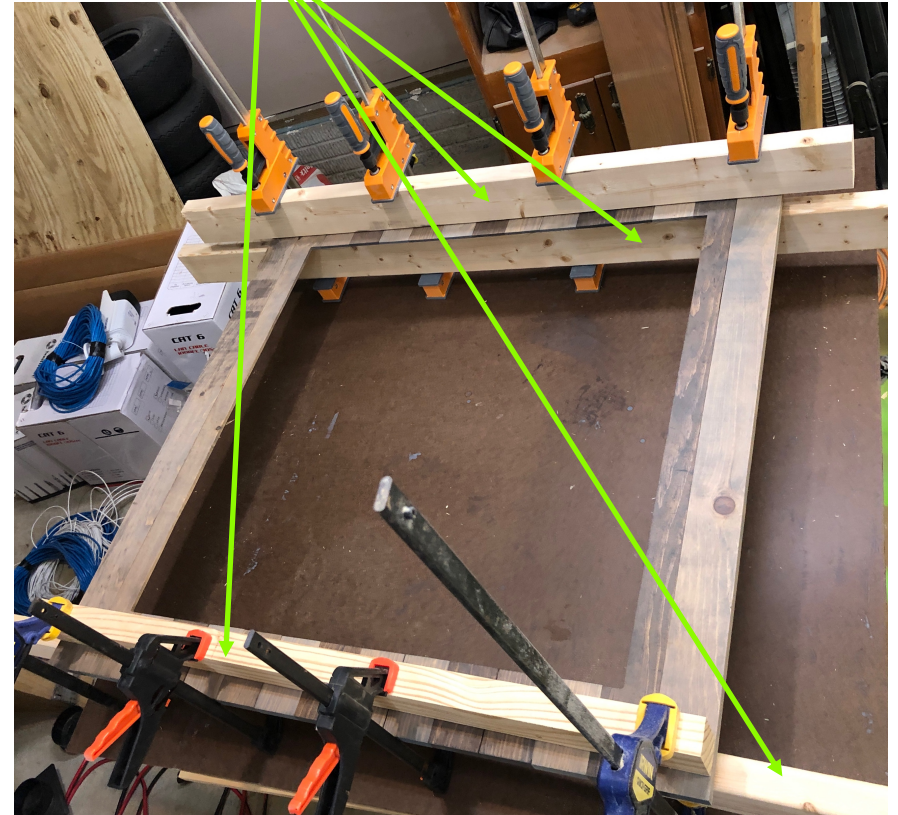

THE GLUE UP – BASED ON FRAME SIZE OF 22” X 17 1/2”

STEP 12

ONCE THE GLUE HAS CURED, INSERT YOUR GLASS, YOUR PICTURE, AND THEN YOUR BACKERBOARD CUT IN STEP 4.

THEN, EITHER USING YOUR POINT GUN OR PUSH POINTS, SECURE THE ITEMS INSERTED AROUND THE FRAME. INSERT AT LEAST 2 POINTS ON EACH SIDE OF THE FRAME.

THEN, MEASURE TO CENTER AND INSTALL YOUR WALL HANGER ON THE HARDWOOD SUPPORT BOARD, AND YOU'RE ALL FINISHED!

